

ACCUD

ACCURATE MEASUREMENT



See full product range at: accud.nz

Digital Caliper with Interchangeable Points

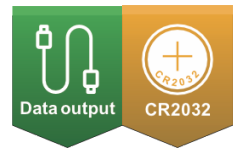

Series 149

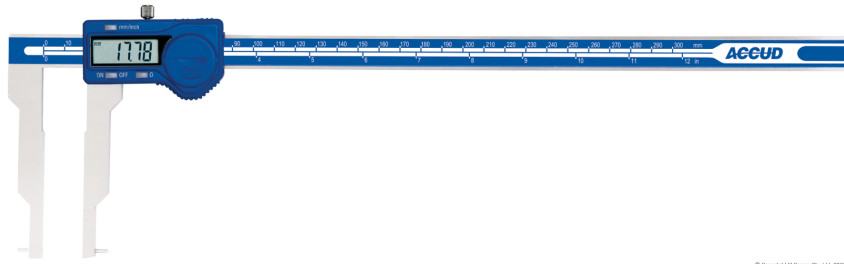

Features

Supplied with 4 pairs of points and one zero setting block for external measurement
 Resolution: 0.01mm/0.0005"
 Buttons: on/off, zero, mm/inch
 Automatic power on/off
 Data output (cable code: 100-11 or 100-12)
 Made of stainless steel

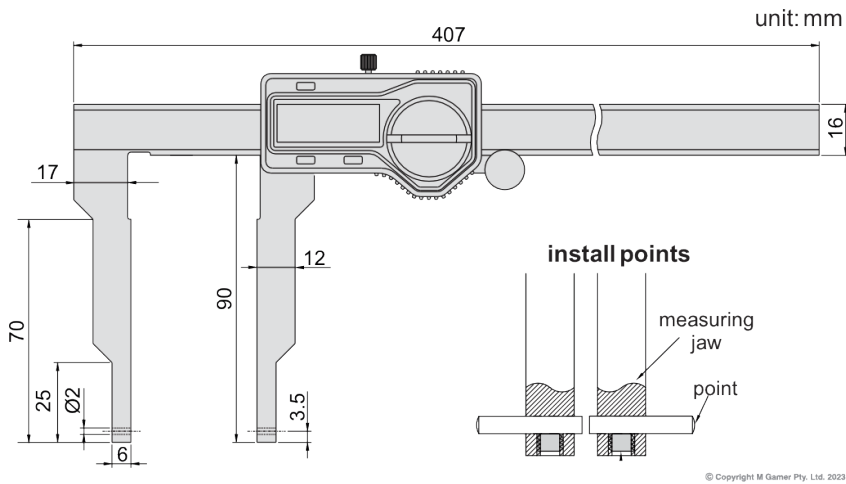

Specifications

Part No	Specification
AC-149-012-11	Point: short spherical/flat points Range: 24-324mm/1-12.7" (internal), 0-288mm/0-11.3" (external) Accuracy: ±0.04mm Application: spherical points for grooves/inside hole, (small hole) flat points for external grooves
	Point: long spherical/flat points Range: 40-340mm/1.5-13.3" (internal), 0-272mm/0-10.7" (external) Accuracy: ±0.04mm Application: spherical points for grooves/inside hole, (large hole) flat points for external grooves
	Point: spherical spherical/blade points Range: 24-324mm/1-12.7" (internal), 0-288mm/0-11.3" (external) Accuracy: ±0.04mm Application: for narrow grooves (small hole)
	Point: long spherical/blade points Range: 40-340mm/1.5-13.3" (internal), 0-272mm/0-10.7" (external) Accuracy: ±0.04mm Application: for narrow grooves (large hole)