

# ACCUD

## ACCURATE MEASUREMENT



See full product range at: [accud.nz](http://accud.nz)



# Contact Points

Series 270

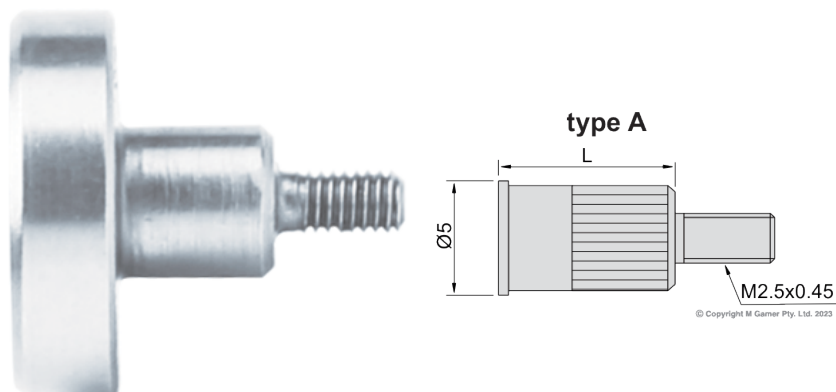

© Copyright M Gamer Pty. Ltd. 2023

## Specifications

Part No	D	Type	Material	Point
AC-270-005-01	-	A	steel	Flat Point
AC-270-005-02	-	A	steel	Flat Point
AC-270-005-11	Ø10	B	steel	Flat Point
AC-270-005-12	Ø15	B	steel	Flat Point
AC-270-005-13	Ø20	B	steel	Flat Point
AC-270-005-14	Ø25	B	steel	Flat Point
AC-270-005-15	Ø30	B	steel	Flat Point
AC-270-005-21	-	D	carbide	Flat Point
AC-270-006-01	Ø0.45	A	steel	Needle Point
AC-270-006-02	Ø0.45	A	steel	Needle Point
AC-270-006-03	Ø1	A	carbide	Needle Point
AC-270-006-04	Ø1	A	carbide	Needle Point
AC-270-006-05	Ø1	A	carbide	Needle Point
AC-270-006-06	Ø1	A	carbide	Needle Point
AC-270-006-07	Ø1	A	carbide	Needle Point
AC-270-006-08	Ø1	A	carbide	Needle Point
AC-270-006-09	Ø1.5	A	carbide	Needle Point
AC-270-006-10	Ø1.5	A	carbide	Needle Point
AC-270-006-11	Ø1.5	A	carbide	Needle Point
AC-270-006-12	Ø1.5	A	carbide	Needle Point
AC-270-006-13	Ø1.5	A	carbide	Needle Point
AC-270-006-14	Ø2	A	carbide	Needle Point
AC-270-006-15	Ø2	A	carbide	Needle Point
AC-270-006-16	Ø2	A	carbide	Needle Point

Part No	D	Type	Material	Point
AC-270-006-17	Ø2	A	carbide	Needle Point
AC-270-006-21	-	B	steel	Needle Point
AC-270-006-22	-	B	steel	Needle Point
AC-270-006-23	-	B	steel	Needle Point
AC-270-006-24	-	B	steel	Needle Point
AC-270-007-01	-	-	steel	Knife Edge Point
AC-270-010-16	Ø10	C	ceramic	Flat Point